



Processing guide for Multiflex™ TES TTA

Multiflex™ TES TTA is designed for injected application: easy mold feeding, for single or multiple cavities geometries are possible due to high fluidity. Please find below some indications to follow for injection process. Of course, this doesn't replace molder know-how, every mold having its own specificity, but this document is useful for any initial parameter choice.

Multiflex™ TES TTA can be injected between their melting temperatures from 170°C to 220°C. In this temperature range, materials are stable, above, thermal degradation occurs, resulting in yellowing and significant odor emanation. On a general point of view, viscosity of SEBS based material is principally dependant of applied shear, so Multiflex must be injected with high injection speed. Multiflex™ TES TTA has been designed to enlarge process window, and can be injected at medium speed.

Pre-drying

As Multiflex™ TES TTA is not humidity sensitive, Pre-drying is not needed. In case of "incident", pre-drying at 40°C during 8 hours is recommended.

Machinery cleaning

High flow thermoplastic must be used, PEHD, PELD or PP.

Coloring

Multiflex™ TES TTA could be colorable by using colorants but not pigments. Those would wipe out the transparency. Colored masterbatch based on PP, PE or ethylene copolymers can be used but in order to keep the high level of transparency, it would be necessary to develop a color masterbatch based on Multiflex™ TTA.

Processing parameters

Screw:

Geometry: Standard injection machine, L/D > 20, Compression rate 2:1 to 3:1 (if higher, risk of thermal degradation)
Screw speed between 100 to 150 rpm ensures through melting of the material without excessive temperature generation. Start with 120 rpm.

Back pressure

Must be between 7 and 15 bars: This will ensure a uniform melt without severe shear heating

Temperatures (°C):

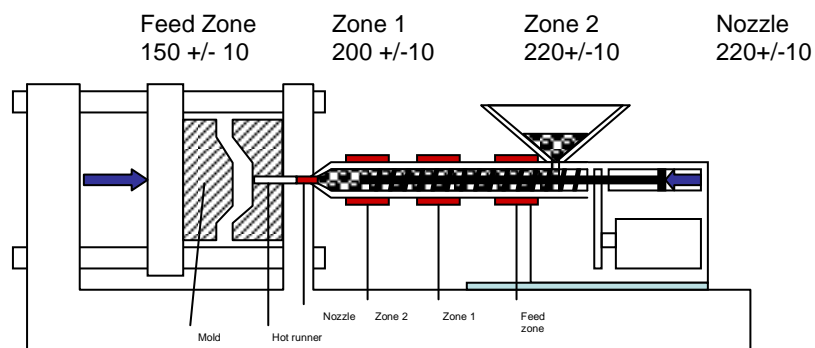



Injection speed:

Injection speed and fill time are highly dependent on part geometry, complexity and gate design. Faster speeds typically result in easier mold filling while lower speeds result in better surface in better surface appearance. High injection speed, around 70% of maximum injection speed should be used initially.

Holding pressure

Start with a pressure equivalent to 30% of maximum injection pressure. Excessive holding pressure can result in distortion in the area of the gate due to elastomeric characteristics of the material

Holding time

3 second can be used to start to ensure sufficient time for gate freeze off.
Holding time can be slowly reduced until changes in part appearance of weight occur.

Mold

Use conventional mold design (venting, finish, draft)
Temperature: from 10°C to 60°C, but typically chosen in the range 20-30°C gives good results.
To improve the transparency, hot mold is recommended.

Hot Runners

Apply a temperature of 200°C +/- 10

Recycling

Multiflex™ TES TTA is 100% recyclable without properties loss. We recommend a maximum level of 10% of recycling material in virgin material.

LIMITED WARRANTY INFORMATION - PLEASE READ CAREFULLY

The information contained herein is offered in good faith and is believed to be accurate.

However, because conditions and methods of use of our products are beyond our control, this information should not be used in substitution for customer's tests to ensure that Multibase's products are safe, effective, and fully satisfactory for the intended end use. Suggestions of use shall not be taken as inducements to infringe on any patent. Multibase's sole warranty is that the product will meet the Multibase sales specifications in effect at the time of shipment. The exclusive remedy for breach of such warranty is limited to refund of purchase price or replacement of any product shown to be other than as warranted.

MULTIBASE SPECIFICALLY DISCLAIMS ANY OTHER EXPRESS OR IMPLIED WARRANTY OF FITNESS FOR A PARTICULAR PURPOSE OR MERCHANTABILITY. MULTIBASE DISCLAIMS LIABILITY FOR ANY INCIDENTAL OR CONSEQUENTIAL DAMAGES.

Multiflex™ is a trademark from Multibase.